

<p><b>Technique</b></p>	<p>During new design or upgrades to existing transmission systems, consider the use of fiber optic systems in place of metallic cable systems.</p>
 <h2 style="margin: 0;">FIBER OPTIC SYSTEMS</h2> <p style="margin: 0;"><i>Use of fiber optics provides superior maintainability characteristics and significant maintenance advantages over metallic cable</i></p>	
<p><b>Benefits</b></p>	<p>Properly designed fiber optic transmission systems will last for long periods of time without any preventive maintenance and can offer reduced maintenance downtime and repair costs. Well-built optical transmission lines and couplers are relatively immune to electromagnetic interference, adverse temperature, and moisture conditions and can be used for underwater cable. An optic fiber can be 20 times lighter and five times smaller than copper wire and still carry far more energy. Using fiber optic control circuits provides electrical isolation for safety in hazardous environments. Because optical cables carry no current they are safe to use in explosive environments and eliminate the hazards of short circuits in metal wires and cables.</p>
<p><b>Key Words</b></p>	<p>Fiber Optics, Maintainability</p>
<p><b>Application Experience</b></p>	<p>Kennedy Space Center Ground Support Systems (e.g., Launch Processing System, Ground Communications System).</p>
<p><b>Technical Rationale</b></p>	<p>Fiber optics can enhance the transmission quality, capacity, and safety environment of the system. The system designer should carefully weight the pros and cons of fiber optics vs. copper, microwave, or satellite for the transmission medium. Optical fiber, if cabled and installed properly, will last for years without any preventive maintenance. Reliability of optical cable is very good, and will enhance system availability, minimize downtime for maintenance, and reduce repair costs.</p>
<p><b>Contact Center</b></p>	<p><b>Kennedy Space Center (KSC)</b></p>

## **Fiber Optic Systems** **Technique OPS-8**

### **Components and Operation**

The basic elements found in fiber optic systems are a transmitter, fiber optic cable, receiver, and connectors. Figure 1 illustrates the main parts of a fiber optic system. The following is a brief description of these elements and their function:

- The Transmitter converts an electrical signal to a light signal. The transmitter consists of a driver and a source. The input to the driver is the signal from the equipment being served. The driver circuit changes the input signal into a form required to operate the source. The source, either a light-emitting diode (LED) or laser diode, does the actual conversion.
- The Fiber Optic Cable is the medium for carrying the light signal. The main parts of a fiber cable are the optical fiber, cladding, buffer jacket, buffer, strength members, and jacket. Figure 2 illustrates the main parts of a single fiber cable. The optical fiber contains two concentric layers called the core and the cladding. The inner core is the light-carrying part. The surrounding cladding provides the difference in refractive index that allows total internal reflection of light through the core. The buffer is the plastic coating applied to the cladding.

Cable buffers are one of two types, loose or tight. The loose buffer uses a hard plastic tube having an inside diameter several times that of the fiber. One or more fibers lie within the buffer tube. The tube isolates the fiber from the rest of the cable and the mechanical forces acting on it. The buffer becomes the load bearing member. As the cable expands and shrinks with changes in

temperature, it does not affect the fiber as much. A fiber has a lower temperature coefficient than most cable elements, meaning that it expands and contracts less. The tight buffer has a plastic directly applied over the fiber coating.

This construction provides better crush and impact resistance; however, it does not protect the fiber as well from stresses of temperature variations. Because the plastic expands and contracts at a different rate than the fiber, contractions caused by variations in temperature can result in loss-producing microbends. Tight buffers are more flexible and allow tighter turn radii. Therefore; tight tube buffers are useful for indoor applications where temperature variations are minimal and the capability to make tight turns inside walls is desired.

Strength members add mechanical strength to the fiber cable. The most common strength members are Kevlar Aramid yarn, steel, and fiberglass epoxy rods. During and after installation, the strength members handle the tensile stresses applied to the cable so that the fiber is not damaged. Kevlar is most commonly used when individual fibers are placed within their own jackets. Steel and fiberglass members find use in multi-fiber cables. Steel offers better strength than fiberglass, but may not be the best choice for maintaining an all dielectric cable. Steel also attracts lightning, whereas fiber does not. The jacket-like wire insulation provides protection from the effects of abrasion, oil, ozone, acids, alkali, solvents, etc. The choice of jacket material depends on the degree of resistance required for different influences and costs.

- The Receiver accepts the light signal and converts it back to an electrical signal. The receiver contains a detector, amplifier, and

an output section. The amplifier enhances the attenuated signal from the detector. The output section performs many functions such as: separation of the clock and data, pulse reshaping and timing, level shifting to ensure compatibility (TTL, ECL, etc.) and gain control.

- **Connectors and splices**, which link the various components of a fiber optic system, are vital to system performance. A connector is defined as a disconnectable device used to connect a fiber to a source, detector, or another fiber. It is designed to be easily connected and disconnected many times. A splice is a device used to connect one fiber to another permanently. Connection by splices and connectors couples light from one component to another with as little loss of optical power as possible. The key to a fiber optic connection is precise alignment of the mated fiber cores (or spots in single-mode fibers) so that nearly all the light is coupled from one fiber across the junction to the other fiber. Contact between the fibers is not required. However, the demands of precise alignment on small fibers create a challenge to the designer of the connector or splice.

Maintainability design features that should be addressed in the design for fiber optic systems should provide for fault localization and isolation, modular replacement, and built-in test and check-out capability.

### ***Improvements***

Fiber optics systems offer many benefits. In sensing systems, sensitive electronics can be isolated from shock, vibration, and harsh environments, resulting in more economical packaging. The number of repeaters required for low attenuation cable is less than

with conventional systems and for short hauls of less than 10 km, no repeaters are necessary. In the absence of electrical current, the life of a fiber optic system's components equals the useful life of the control system, the light source, and the electronics. Maintenance and repair costs are reduced dramatically. Installation costs of fiber optic cables are lower than metal cables because the shipping and handling costs are about one-fourth and labor costs one-half that of current metal cables.

### ***References***

1. RADC-TR-88-124, *Impact of Fiber Optics on System Reliability and Maintainability*, June 1988.
2. RADC-TR-80-322, *Failure Rates for Fiber Optic Assemblies*, October 1980.
3. AWP, *Technician's Guide for Fiber Optics*, 1987.

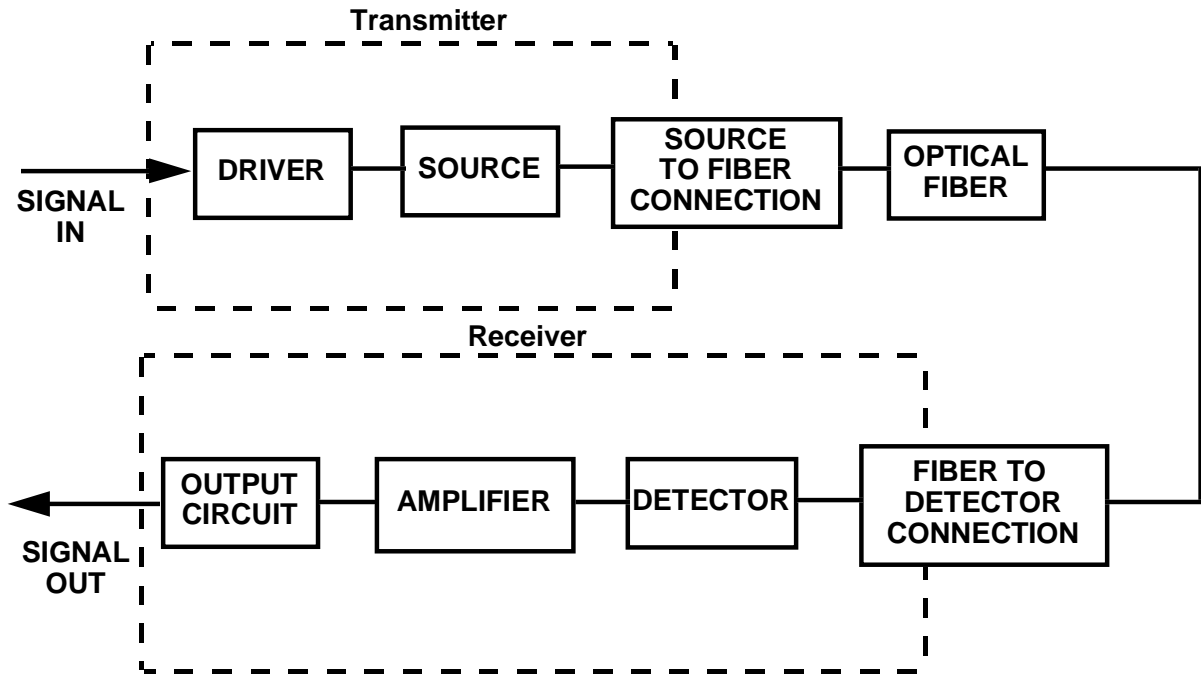

Figure 1. Basic Fiber Optic Link

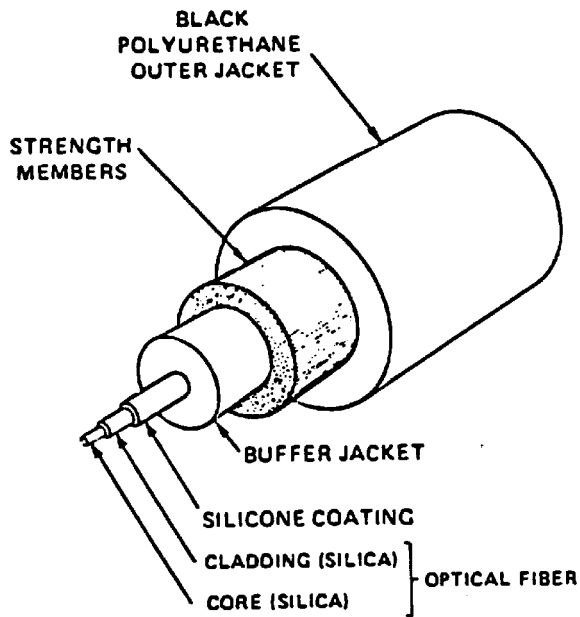

Figure 2. Parts of a Fiber Optic Cable